

# Grease Guardian®

X Range

*"Grease Guardian outperforms any passive grease trap"*

THOMAS MILLER  
CHEF



## UNDER SINK INSTALLATION

Automatically separates & removes FOG (fats oils and grease), from kitchen waste water

Solids filtration as standard

Reduces pump out requirements

Easy to install & maintain

Collected waste can be recycled

Automatic controls

Approved under PDI and ASME

Full customer support



BS EN ISO 9001:2008



[www.fmenvironmental.com](http://www.fmenvironmental.com)



### THREE-STAGE OPERATION SYSTEM

#### STAGE 1 Solids Collection

Wastewater from the kitchen is directed through the inlet of the **Grease Guardian**® where a removable strainer basket collects any solid debris.

#### STAGE 2 Grease & Oil Separation

Grease in the wastewater floats to the surface and is trapped while the clear water leaves the unit and enters the drainage system.

#### STAGE 3 Self Cleaning & Grease Removal

The timer-driven heating element is activated to liquefy grease, which is then removed by the skimming wheel and deposited into a portable container for recycling. Can be connected to: pot wash sinks, pre-rinse sinks, combi ovens, Chinese cookers and floor drains.

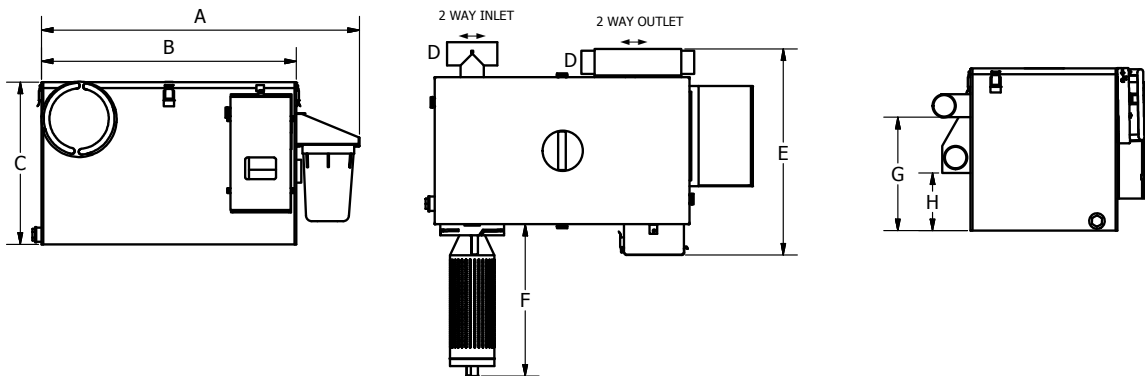

Model	Length (A) INCLUDES CONTAINER	Length (B) TANK ONLY	Height (C)	Inlet/Outlet (D)	Width (E) INCLUDES PANEL	Basket (F) CLEARANCE NEEDED	Inlet Height (G) INLET	Outlet Height (H) OUTLET	Max Flow
<b>X15</b>	788	623	341	50	559	401	214	85	0.94 l/sec
<b>X25</b>	826	658	421	50	559	401	294	160	1.58 l/sec
<b>X35</b>	1039	876	421	80	610	401	282	187	2.21 l/sec

ALL DIMENSIONS IN MM

**Specification:** Automatic grease trap with inbuilt FOG treatment, FOG removal and self cleaning mechanisms. 16 Gauge 304 Stainless Steel with bright finish, 25 Watt, 230VAC; 50Hz Motor. 600 Watt Heater with Thermal Cut Out included. Logic Controller with Backlit Display. Skimming Drum is nominally capable of skimming 5 l per hour. Can be connected to pot wash sinks, pre-rinse sinks, combi ovens, Chinese cookers, floor drains and most grease producing kitchen appliances. UL, PDI, CSA, and ASME tested. Please note dimensions are subject to change without notice.

GGXEURV-1



#### Manufacturers

FM Environmental  
Greenbank Industrial Estate  
Newry BT34 2QX  
Northern Ireland  
T: +44(0)28 302 66616  
F: +44(0)28 302 63233  
E: sales@greaseguardian.com  
[www.greaseguardian.com](http://www.greaseguardian.com)

#### Malta

FM Environmental (Malta) Ltd  
Water Technology House  
A15B Industrial Estate  
Marsa, Malta  
T: +356 2122 6172  
F: +356 2122 6171  
E: fmmalta@fmenvironmental.com  
[www.fmenvironmental.com](http://www.fmenvironmental.com)

Authorised distributor:



[www.greaseguardian.com](http://www.greaseguardian.com)

