

Grease Guardian®

Frontline Engineering

"Grease Guardian lets me focus only on my job"

JESSICA SMITH
PASTRY CHEF



MANUAL GREASE TRAP RANGE

Suitable for coffee shops, confectioneries, snack bars, patisseries and other small catering applications

Stainless steel fabrication

Intelligent design

Traps food waste & grease

Small foot print and portable

Easy to install and maintain

Full customer support



BS EN ISO 9001:2008



www.fmenvironmental.com



THREE-STAGE OPERATION SYSTEM

STAGE 1 Solids Collection

Wastewater from the kitchen is directed through the inlet of the **Grease Guardian**® where a removable strainer basket collects any solid debris.

STAGE 2 Grease & Oil Separation

Grease in the wastewater floats to the surface and is trapped while the clear water leaves the unit and enters the drainage system.

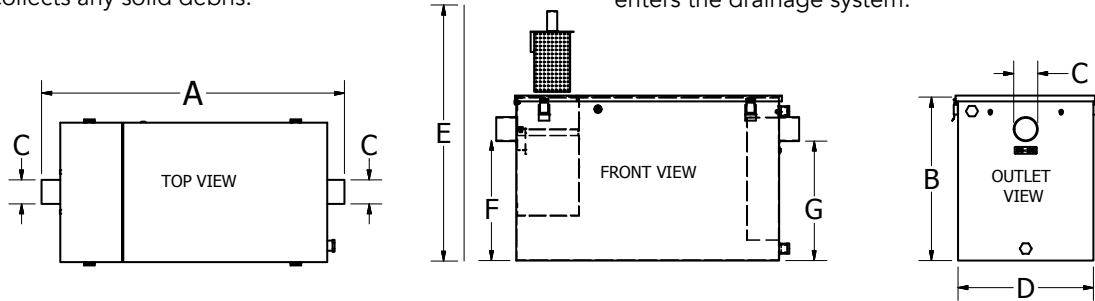

Model	Length (A) <small>INCLUDES CONNECTIONS</small>	Height (B) <small>TANK ONLY</small>	Inlet/Outlet (C)	Width (D)	Basket clearance (E)	Inlet Height (F)	Outlet Height (G)	Max flow (litres/sec)
GT1	700	323	60	340	500	205	205	0.75l/s
GT2	760	414	60	340	620	302	302	1.25l/s
GT3	800	428	60	340	667	340	298	2.00l/s
GT4	940	455	89	356	718	331	231	2.75l/s
GT5	1000	455	89	400	718	331	231	3.5l/s

ALL DIMENSIONS IN MM

MANUAL GREASE TRAP RANGE WITH FAT-BIO DOSING OPTION

STAGE 3 Dosing

The trapped grease can be treated by using the FatBio solution which combines a lipase producing non pathogenic bacteria with nutrients and enzymes.

Fat-Bio Grease Solution

- Unique liquid biological formulation
- Completely bio-degradable with minimal environmental impact
- Complies with (EC) No 648/2004 Regulation
- Product requires no hazard labelling and is therefore safe to transport, to store and to use



GTREV-1



Manufacturers

FM Environmental
Greenbank Industrial Estate
Newry BT34 2QX
Northern Ireland
T: +44(0)28 302 66616
F: +44(0)28 302 63233
E: sales@greaseguardian.com
www.greaseguardian.com

Malta

FM Environmental (Malta) Ltd
Water Technology House
A15B Industrial Estate
Marsa, Malta
T: +356 2122 6172
F: +356 2122 6171
E: fmmalta@fmenvironmental.com
www.fmenvironmental.com

Authorised distributor:



www.greaseguardian.com

